

Preliminary Development Plan for the Replat of Creekside at Eagle Mountain Sec 10 & 11, T10N, R21E



PROJECT LOCATION: Show Low, AZ
CLIENT INFORMATION: RFR Partners, LLC
 P.O. Box 2949
 Show Low, AZ 82902

PROJECT NO: 180026-18001
CLIENT PROJECT NO:

PROJECT NOTES:

ISSUED:

Painted Sky Engineering and Surveying, LLC

1801 West Deuce of Clubs, Suite 230
 Show Low, AZ 85901
 PH: (928) 537-7218 FX: (928) 537-8422

<http://www.paintedskyes.com>

VICINITY MAP:

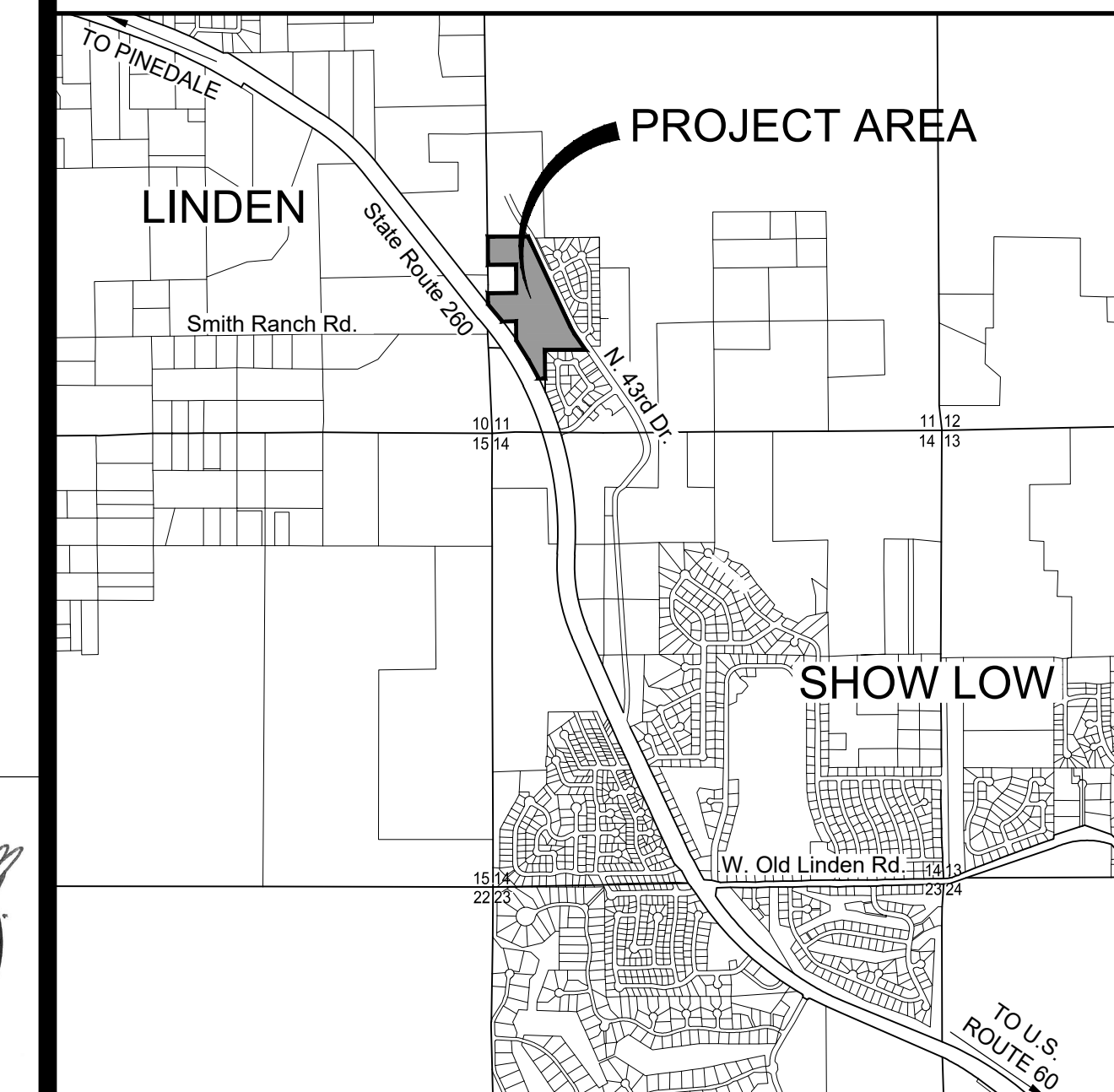

FLOOD PLAIN

FIRM MAP, #04017C4488F SHOWS THIS PROPERTY TO BE LOCATED IN A 'ZONE X, "AREAS DETERMINED TO BE OUTSIDE THE 0.2% ANNUAL CHANCE FLOODPLAIN". MAP DATED AUGUST 17, 2015.

UTILITIES

ELECT. - NAVOPACHE ELECTRICAL COOPERATIVE
 SEWER - CITY OF SHOW LOW
 CABLE TELEVISION - CABLE ONE
 WASTE DISPOSAL - WASTE MANAGEMENT
 FIRE PROTECTION - TIMBER MESA FIRE DISTRICT
 WATER - CITY OF SHOW LOW
 NATURAL GAS - UNISOURCE ENERGY

AREA

Gross Area of Project = 19.24 AC

Total No. of Lots = 57 Lots

Min = 0.069 AC
 Max = 0.67 AC
 Avg = 0.34 AC

Tract A (Private Roadway and Utility Easements) = 2.84 AC
 Tract B (Public Drainage Basin) = 1.99 AC
 Tract C (Open Space & Recreational Use) = 0.31 AC
 Tract D (Commercial Use) = 0.5 AC
 Tract E (Public Utility Easement) = 0.05 AC
 Tract F (Parking, Landscaping, Open Space & Roadway Access) = 0.19 AC
 DU/Gross Acre = 1

Private Roads = 3,651 LF

PROJECT NOTES

- PREVIOUSLY CONSTRUCTED WATER, SEWER, AND ROADWAY IMPROVEMENTS THAT WILL BE USED IN THE REPLATTED SUBDIVISION WILL BE INTERGRADED "AS-IS". NO ATTEMPT WILL BE MADE TO CONFIRM THAT THESE IMPROVEMENTS WERE CONSTRUCTED IN ACCORDANCE WITH THE APPROVED PLANS OR SPECIFICATIONS, DATED 10/11/06 BY IRONSIDE ENGINEERING, UNLESS IT IS OBVIOUS THAT THEY WERE INSTALLED IMPROPERLY. THOSE IDENTIFIED AS BEING IMPROPERLY INSTALLED WILL BE CORRECTED. ALL IMPROVEMENTS, NOT YET CONSTRUCTED AND SHOWN ON THE APPROVED PLANS, WHICH WILL BE NECESSARY FOR THIS REPLAT WILL BE CONSTRUCTED IN ACCORDANCE WITH THOSE APPROVED PLANS AND SPECIFICATIONS. NEW OR REVISED IMPROVEMENTS, NOT SHOWN ON THE APPROVED PLANS WILL BE DESIGNED AND SUBMITTED TO THE CITY FOR APPROVAL. ALL INFRASTRUCTURE IMPROVEMENTS THAT WILL BE UTILIZED IN THE RE-PLATTED LOTS, NOT PRESENTLY ACCEPTED BY THE CITY, WILL BE TESTED IN ACCORDANCE WITH CITY REQUIREMENTS. THE ENGINEER OF RECORD WILL PROVIDE AS-BUILT PLANS THAT REFLECT IMPROVEMENT LOCATIONS TO THE BEST OF ITS ABILITY, BASED ON FIELD MEASUREMENTS OF VISIBLE IMPROVEMENTS.
- THERE ARE EXISTING UTILITY AND DRAINAGE IMPROVEMENTS THAT HAVE BEEN INSTALLED, BUT WILL NOT BE NEEDED OR USED FOR THE RE-PLATTED SUBDIVISION. UPON APPROVAL OF THIS PRELIMINARY DEVELOPMENT PLAN, THE FOLLOWING ABANDONMENT OR REMOVAL PROCESSES ARE ACCEPTABLE TO THE CITY.
 - EXISTING DRAINAGE FACILITIES NOT DEEMED NECESSARY PER THE DRAINAGE REPORT MAY BE REMOVED OR ABANDONED IN PLACE.
 - PUBLIC SERVICE UTILITY SERVICES, SUCH AS ELECTRICAL, TELEPHONE, NATURAL GAS, OR CATV, THAT WILL NOT BE REQUIRED FOR THE RE-PLATTED LOTS, WILL BE ABANDONED IN ACCORDANCE WITH THE RESPECTIVE UTILITY SERVICE COMPANIES.

OWNER/DEVELOPER

RFR Partners
 Cory Frampton, Member
 Box 2949
 Show Low AZ 85902

Member _____ Date _____

BENCHMARK

▲ W 1/4 Corner Section 11
 B.L.M. Brass Cap, Stamped "1969"
 Elevation=6208.59

APPROVALS

THIS PLAT IS APPROVED BY COMMISSION ACTION

ON THIS _____ DAY OF _____, 20__

CHAIRMAN-SHOW LOW PLANNING & ZONING COMMISSION

LEGAL DESCRIPTION

CREEKSIDE AT EAGLE MOUNTAIN AS RECORDED IN BOOK 28,
 PAGES 20-23, OF PLATS, NAVAJO COUNTY RECORDERS OFFICE.

ZONING

EXISTING: P.U.D.

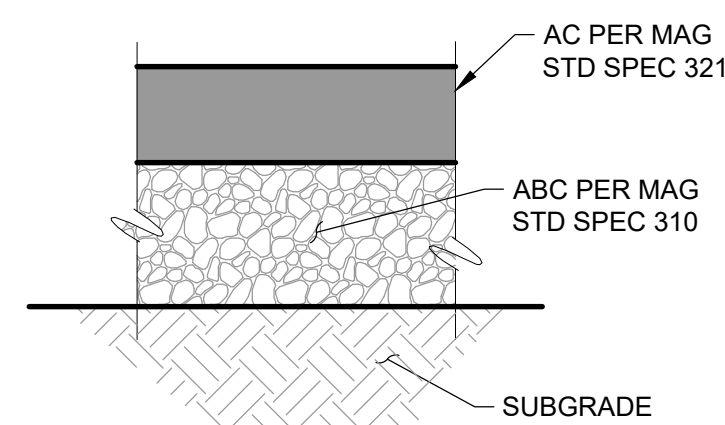

NOTE:
 Thickness of AC and ABC shall be in accordance with the original design, submitted and approved by the City, dated 10/11/06. Due to the partial construction of the roadways in the subdivision, roadway grades, drainage flow direction, curb types and openings, as well as roadway crown will be completed in accordance with the approved plans, dated 10/11/06.

PAVEMENT STRUCTURAL SECTION NO. 1

N.T.S.

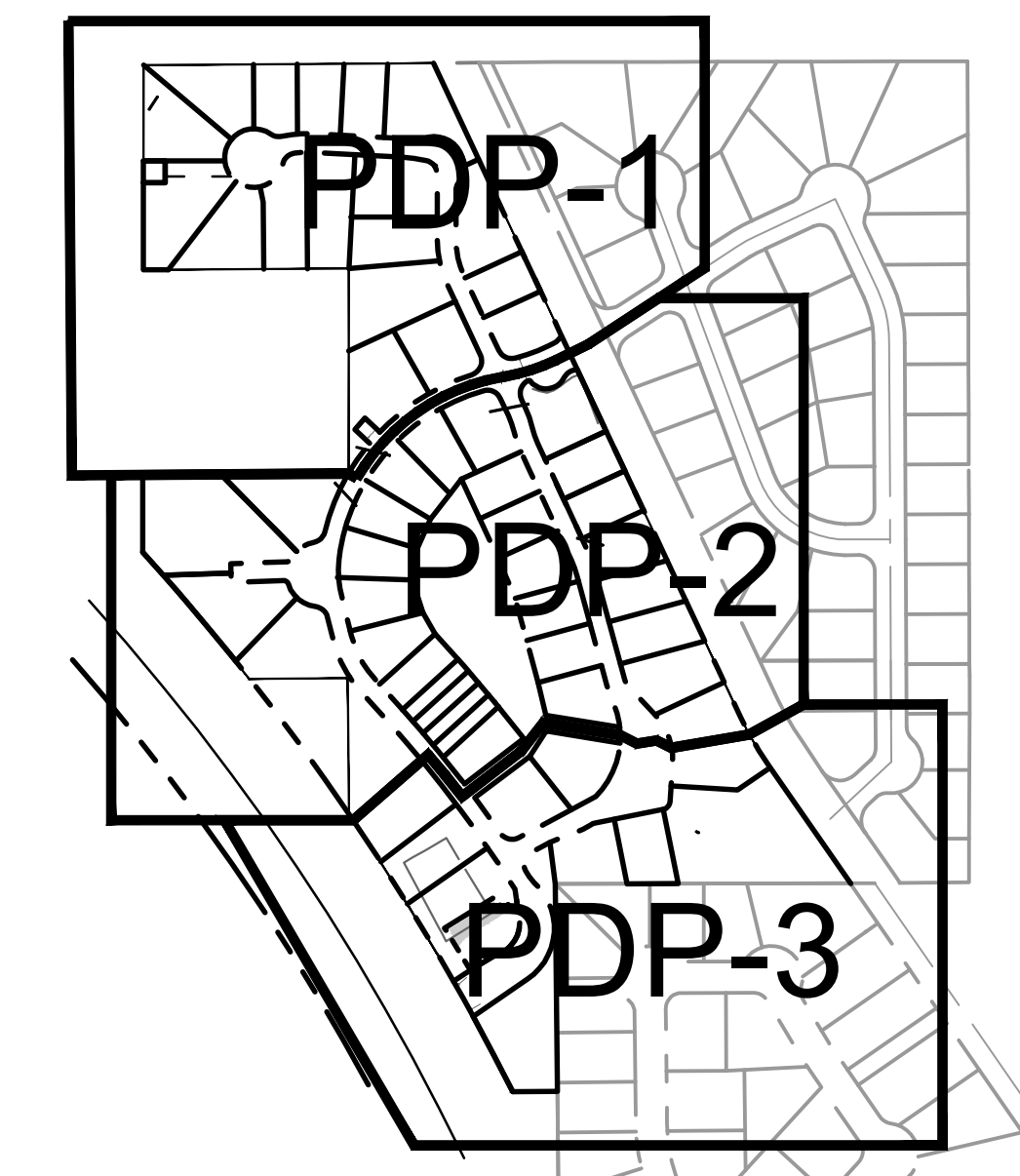

SHEET INDEX

N.T.S.

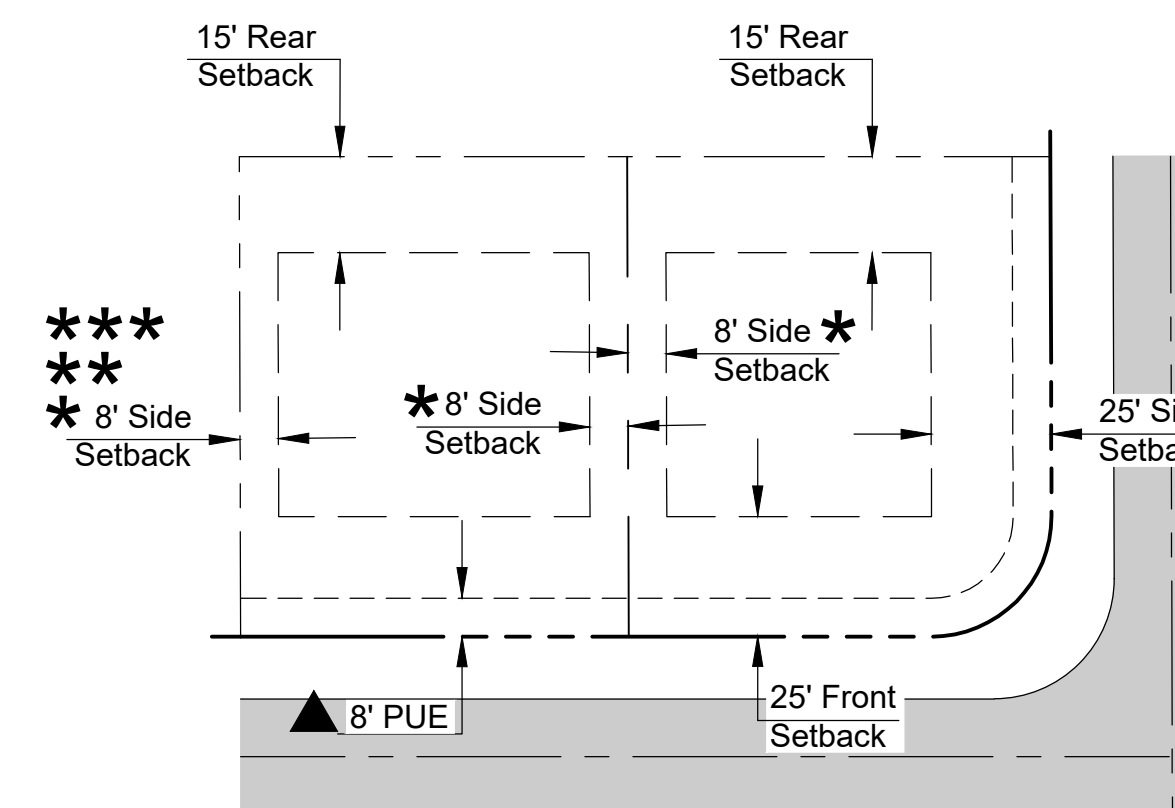

NOTES

- EXISTING BUILDING FOOTINGS AND STEM WALLS ARE LOCATED ON LOTS 37-42.
- THERE IS AN EXISTING BUILDING LOCATED ON TRACT D.

- *** - LOTS 38, 39, 40 AND 41 SHALL HAVE A ZERO (0) FOOT SETBACK LINE ON BOTH SIDES.
- ** - LOT 42 SHALL HAVE AN EIGHT (8) FOOT SETBACK ON THE NORTH-WESTERLY SIDE OF THE LOT.
- * - LOT 37 SHALL HAVE AN EIGHT (8) FOOT SETBACK ON THE SOUTH-EASTERLY SIDE OF THE LOT.
- ▲ - EXCEPT AS SHOWN ON LOTS 1 & 57

TYPICAL SETBACKS

N.T.S.

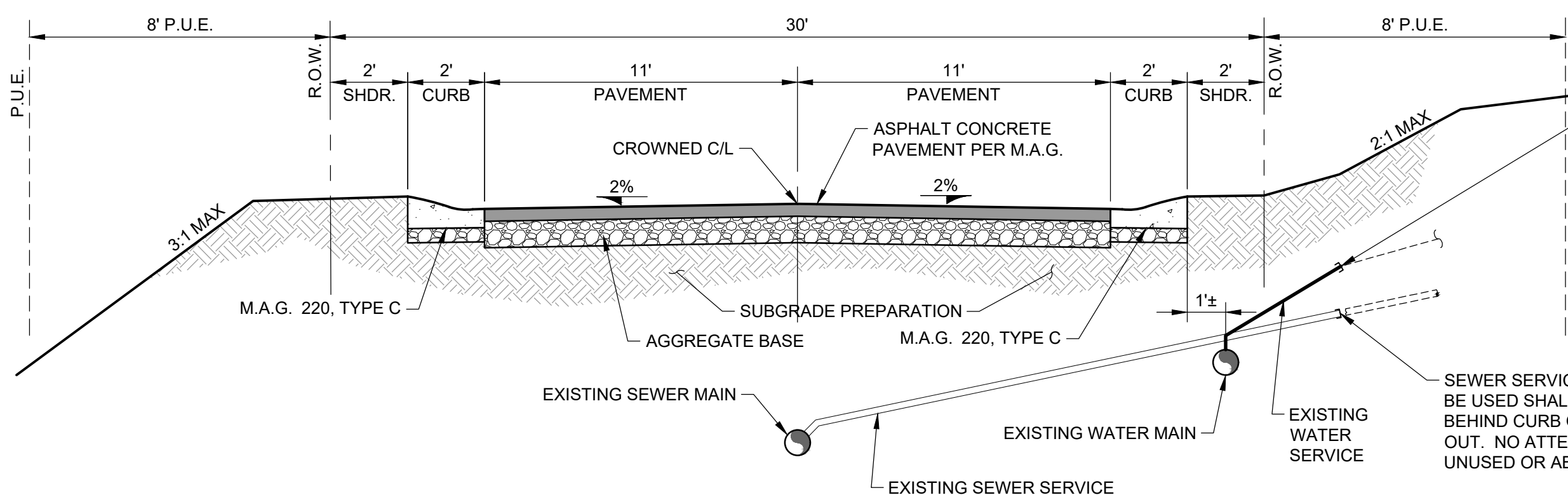

WHERE PRACTICAL, AND THE WATER SERVICE DISCONNECTION WILL NOT UNDERMINE THE EXISTING CURB, GUTTER, OR PAVEMENT SECTION, UNUSED WATER SERVICES WILL BE SHUT OFF AND CUT AT THE WATER MAIN BY CLOSING THE EXISTING CORPORATION STOP AND CUTTING THE PE SERVICE LINE. WHERE THIS DISCONNECTION PROCEDURE WILL INTERFERE WITH THE EXISTING IMPROVEMENTS, THE WATER SERVICE WILL BE EXPOSED AS CLOSE TO THE MAIN AS IS PRACTICAL AND THE SERVICE LINE CAPPED. NO ATTEMPT WILL BE MADE TO REMOVE UNUSED OR ABANDONED SERVICE LINES.

SEWER SERVICE LATERALS, THAT WILL NOT BE USED SHALL BE CUT AND CAPPED 4' BEHIND CURB OR AT THE EXISTING CLEAN OUT. NO ATTEMPT WILL BE MADE TO REMOVE UNUSED OR ABANDONED SERVICE LINES

TYPICAL PUBLIC ROADWAY SECTION

N.T.S.

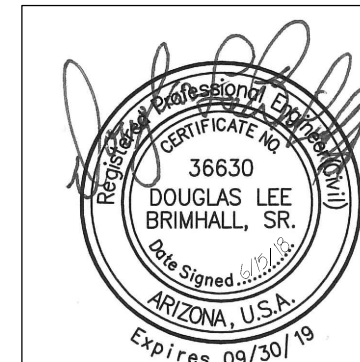

6/15/2018 10:23:05 AM - P:\180026\180026-18001\CAD\SHEETFILES\PDP-1.DWG - DAVID LOWER

U.S.F.S.
SITGREAVES NATIONAL FOREST

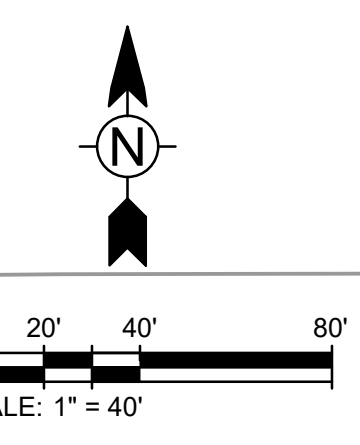

EAGLE MOUNTAIN ESTATES
PHASE 1
BK. 26 OF PLATS, PG. 27 & 28

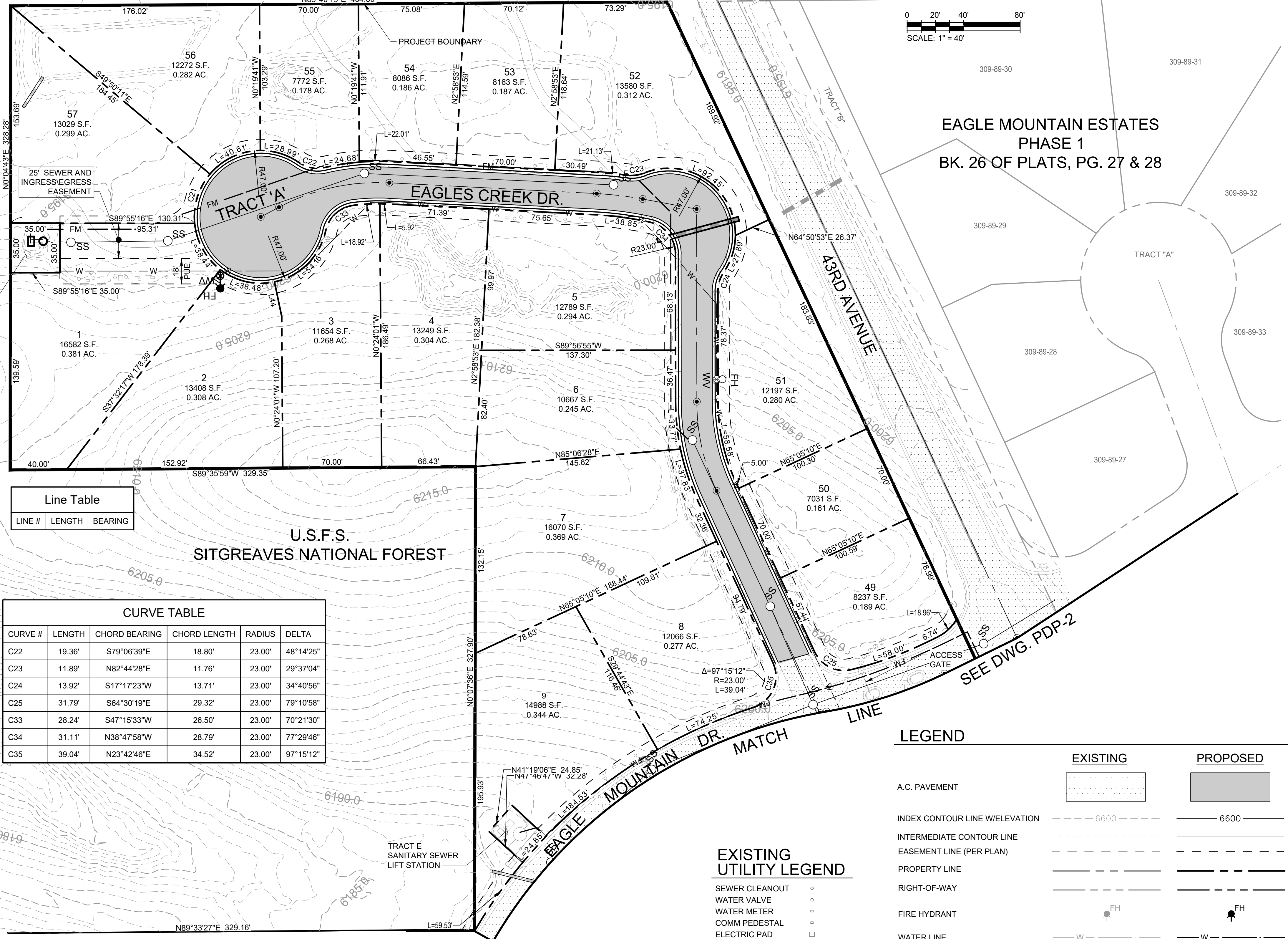

Line Table

LINE #	LENGTH	BEARING
--------	--------	---------

CURVE TABLE

CURVE #	LENGTH	CHORD BEARING	CHORD LENGTH	RADIUS	DELTA
C22	19.36'	S79°06'39"E	18.80'	23.00'	48°14'25"
C23	11.89'	N82°44'28"E	11.76'	23.00'	29°37'04"
C24	13.92'	S17°17'23"W	13.71'	23.00'	34°40'56"
C25	31.79'	S64°30'19"E	29.32'	23.00'	79°10'58"
C33	28.24'	S47°15'33"W	26.50'	23.00'	70°21'30"
C34	31.11'	N38°47'58"W	28.79'	23.00'	77°29'46"
C35	39.04'	N23°42'46"E	34.52'	23.00'	97°15'12"

EXISTING UTILITY LEGEND

- SEWER CLEANOUT ○
- WATER VALVE ○
- WATER METER ○
- COMM PEDESTAL ○
- ELECTRIC PAD □

LEGEND

	EXISTING	PROPOSED
A.C. PAVEMENT		
INDEX CONTOUR LINE W/ELEVATION		
INTERMEDIATE CONTOUR LINE		
EASEMENT LINE (PER PLAN)		
PROPERTY LINE		
RIGHT-OF-WAY		
FIRE HYDRANT		
WATER LINE		
WATER VALVE W/BOX AND COVER		
SEWER FORCE MAIN		
SEWER LINE		
SEWER MANHOLE		
PIPE CULVERT		

PAINTED SKY
Engineering & Surveying, LLC
http://www.paintedskys.com

1801 W. Deuce of Clubs, Suite 230
Show Low, AZ 86001
PH: (928) 637-7218 FX: (928) 637-9422

36630
DOUGLAS LEE BRIMHALL, SR.
Arizona, U.S.A.
Expires 09/30/19

MARK	DATE	DESCRIPTION

RFR Partners, LLC
Show Low, AZ

Preliminary Development Plan

PLAN SHEET

Project No.: 180026-18001
Designed By: DLB
Drawn By: DAL
Checked By: DLB

PDP-1

Bar Measures 1 inch

LEGEND

	EXISTING	PROPOSED
A.C. PAVEMENT		
INDEX CONTOUR LINE W/ELEVATION	- - - - - 6600	- - - - - 6600
INTERMEDIATE CONTOUR LINE	- - - - -	- - - - -
EASEMENT LINE (PER PLAN)	- - - - -	- - - - -
PROPERTY LINE	— — — — —	— — — — —
RIGHT-OF-WAY	- - - - -	- - - - -
FIRE HYDRANT		
WATER LINE	- W - - -	- W - - -
WATER VALVE W/BOX AND COVER	WV	WV
SEWER FORCE MAIN	- FM - - -	- FM - - -
SEWER LINE	- SS - - -	- SS - - -
SEWER MANHOLE	SS	SS
PIPE CULVERT		

CURVE #	LENGTH	CHORD BEARING	CHORD LENGTH	RADIUS	DELTA
C11	88.05'	S72°12'32"W	87.73'	300.00'	16°48'59"
C12	5.06'	S80°11'12"W	5.06'	337.00'	0°51'38"
C13	34.44'	S4°52'18"W	34.40'	200.00'	9°51'59"
C16	49.08'	S7°05'30"E	48.96'	200.00'	14°03'37"
C27	64.36'	S84°15'55"W	54.05'	32.00'	115°14'27"
C28	26.56'	S59°43'15"W	25.10'	23.00'	66°09'08"
C29	35.22'	S18°57'07"W	31.88'	23.00'	87°43'53"
C36	26.43'	N46°44'54"E	25.00'	23.00'	65°50'16"
C37	8.42'	N58°00'28"E	8.03'	8.00'	60°16'31"
C38	10.37'	N54°42'58"W	9.66'	7.99'	74°18'14"
C39	27.65'	N48°33'46"W	26.02'	23.00'	68°53'22"

LINE #	LENGTH	BEARING
L7	24.13'	S 63°48'02" W
L28	75.93'	N 43°04'41" W

EXISTING UTILITY LEGEND

- SEWER CLEANOUT
- WATER VALVE
- WATER METER
- COMM PEDESTAL
- ELECTRIC PAD
- STORM CATCH BASIN

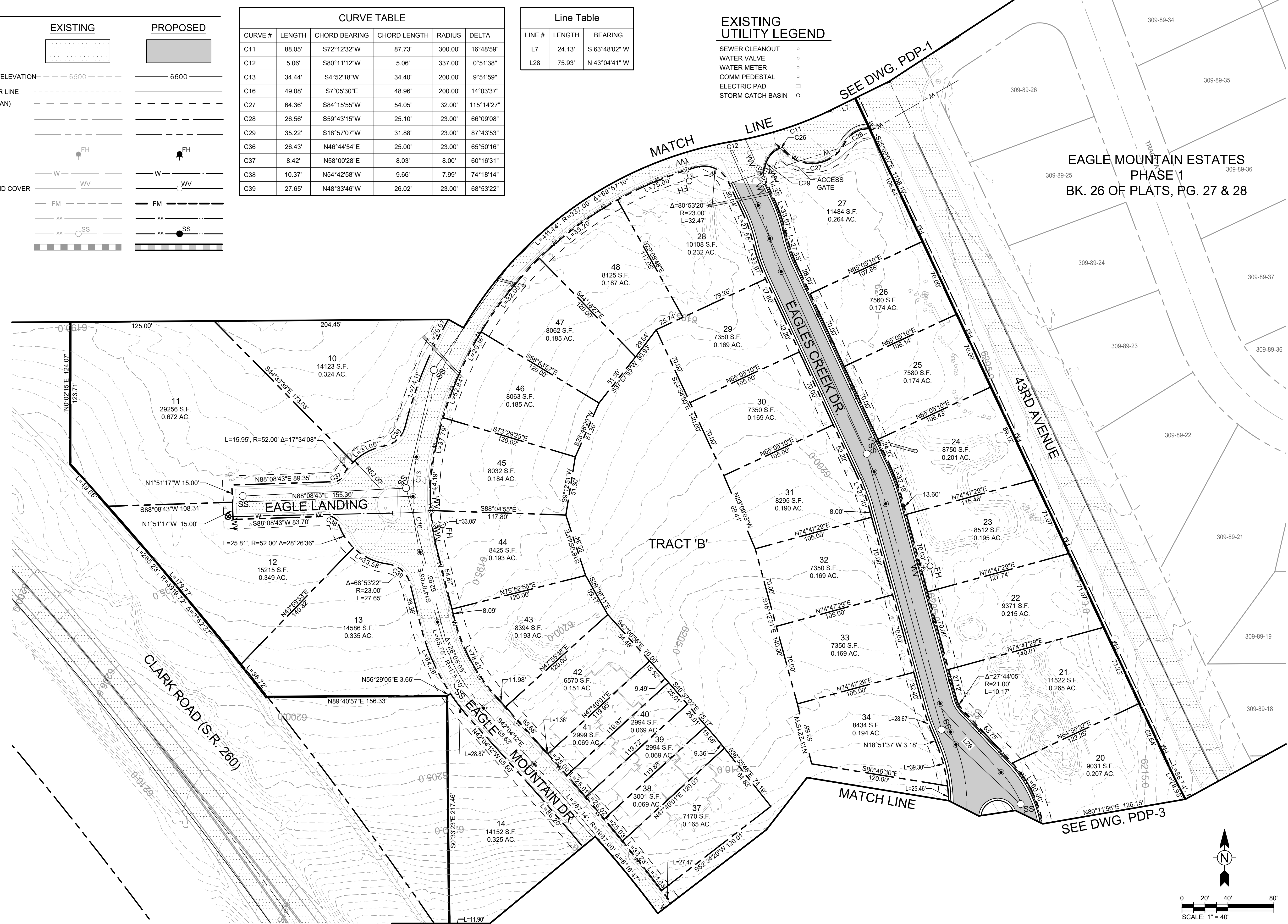

PAINTED SKY
Engineering & Surveying, LLC
1801 W. Deuce of Clubs, Suite 230
Show Low, AZ 86901
PH: (928) 637-7218 FX: (928) 637-8422
<http://www.paintedskysurvey.com>

PROFESSIONAL SEAL OF
DOUGLAS LEE BRIMHALL, SR.
REGISTERED PROFESSIONAL ENGINEER
EXPIRES 09/30/19
ARIZONA, U.S.A.

BY	
MARK	
DATE	
DESCRIPTION	

RFR Partners, LLC
Show Low, AZ

Preliminary Development Plan

PLAN SHEET

Project No.:	180026-18001
Designed By:	DLB
Drawn By:	DAL
Checked By:	DLB

PDP-2

Bar Measures 1 inch

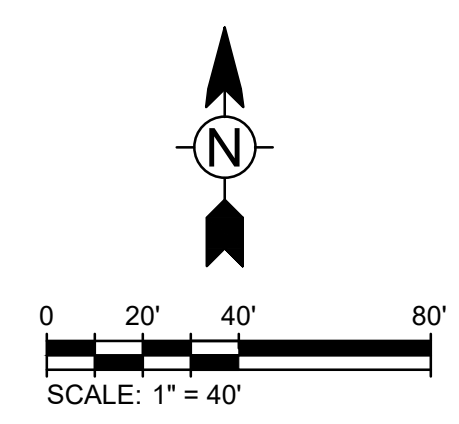

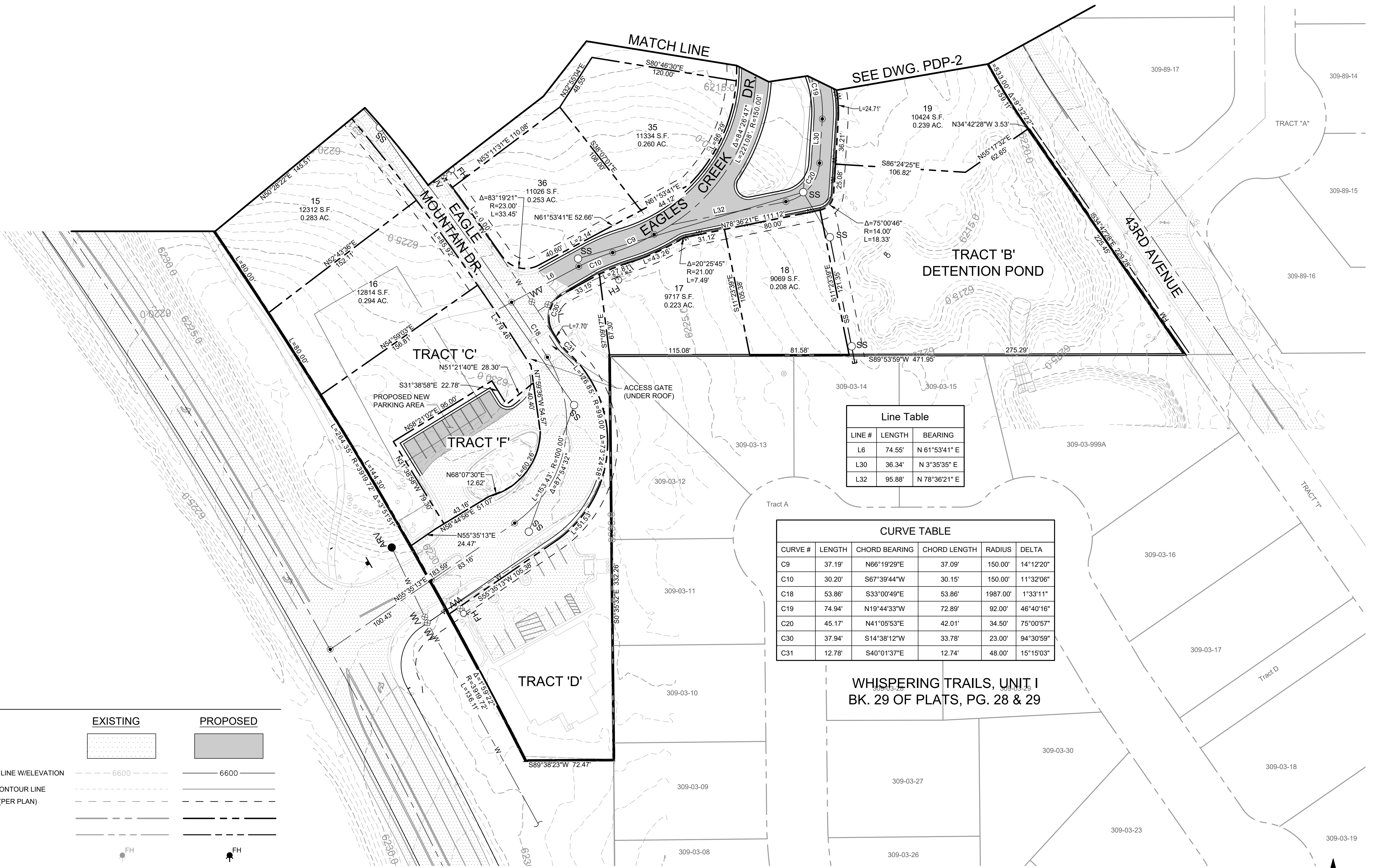

Line Table

LINE #	LENGTH	BEARING
L6	74.55'	N 61°53'41" E
L30	36.34'	N 3°35'35" E
L32	95.88'	N 78°36'21" E

CURVE TABLE

CURVE #	LENGTH	CHORD BEARING	CHORD LENGTH	RADIUS	DELTA
C9	37.19'	N66°19'29"E	37.09'	150.00'	14°12'20"
C10	30.20'	S67°39'44"W	30.15'	150.00'	11°32'06"
C18	53.86'	S33°00'49"E	53.86'	1987.00'	1°33'11"
C19	74.94'	N19°44'33"W	72.89'	92.00'	46°40'16"
C20	45.17'	N41°05'53"E	42.01'	34.50'	75°00'57"
C30	37.94'	S14°38'12"W	33.78'	23.00'	94°30'59"
C31	12.78'	S40°01'37"E	12.74'	48.00'	15°15'03"

LEGEND

	EXISTING	PROPOSED
A.C. PAVEMENT		
INDEX CONTOUR LINE W/ELEVATION		
INTERMEDIATE CONTOUR LINE		
EASEMENT LINE (PER PLAN)		
PROPERTY LINE		
RIGHT-OF-WAY		
FIRE HYDRANT		
WATER LINE		
WATER VALVE W/BOX AND COVER		
SEWER FORCE MAIN		
SEWER LINE		
SEWER MANHOLE		
PIPE CULVERT		

EXISTING UTILITY LEGEND

SEWER CLEANOUT	
WATER VALVE	
WATER METER	
COMM PEDESTAL	
ELECTRIC PAD	
STORM CATCH BASIN	

WHISPERING TRAILS, UNIT I
BK. 29 OF PLATS, PG. 28 & 29

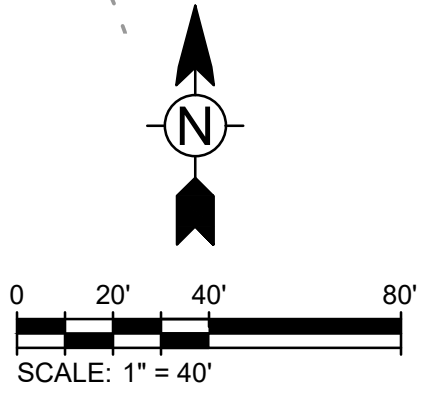

PAINTED SKY
Engineering & Surveying, LLC
http://www.paintedskyes.com
1801 W. Deuce of Clubs, Suite 230
Show Low, AZ 86901
PH: (928) 637-7218 FX: (928) 637-9422

36630
DOUGLAS LEE BRIMHALL, SR.
AZ00000001
Arizona, U.S.A.
Expires 09/30/19

BY	DATE	DESCRIPTION

RRF Partners, LLC
Show Low, AZ
Preliminary Development Plan

PLAN SHEET

Project No.:	180026-18001
Designed By:	DLB
Drawn By:	DAL
Checked By:	DLB

PDP-3

Bar Measures 1 inch